

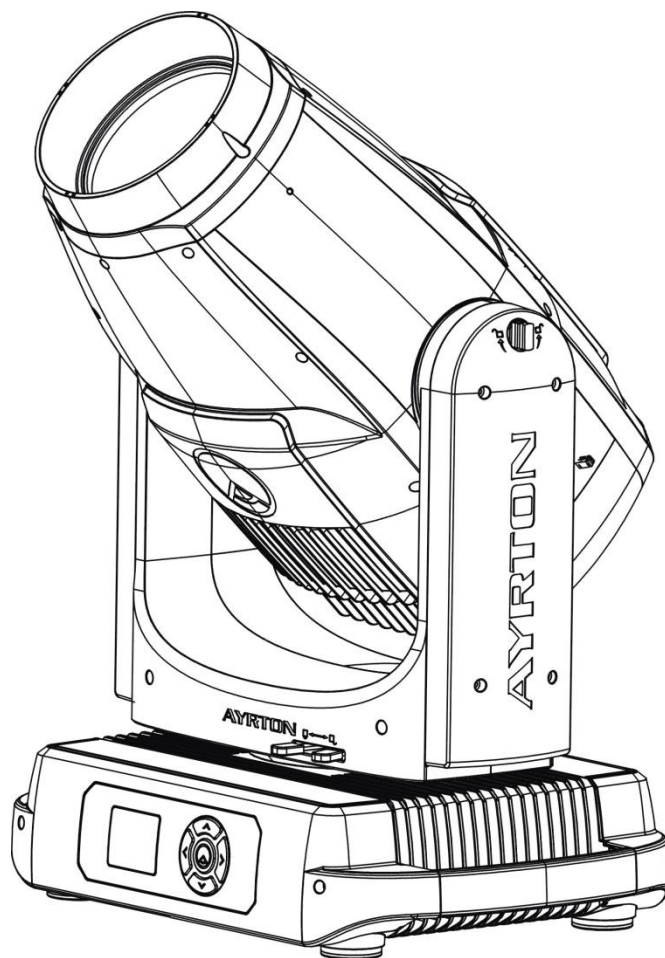

Manuel d'utilisation



perseo^s

KEEP THIS MANUAL FOR FUTURE NEEDS



CONTENTS

1. SAFETY INSTRUCTIONS	2
2. FEATURES	4
3. FIXTURE OVERVIEW	6
4. DIMENSIONAL DRAWINGS	7
5. INSTALLATION INSTRUCTIONS	10
6. DMX-512 CONTROL CONNECTION	13
7. DMX-512 CONNECTION WITH DMX TERMINATOR	13
8. DEVICE DMX START ADDRESS SELECTION	14
9. OPERATING INSTRUCTIONS OF THE INTERNAL DMX WIRELESS SYSTEM	14
10. DISPLAY	16
11. DMX PROTOCOL	32
12. ERROR MESSAGES	44
13. CLEANING AND MAINTENANCE	48

1. SAFETY INSTRUCTIONS

1.1. IMPORTANT SAFETY WARNING

This device has left the factory in perfect condition. In order to maintain this condition and to ensure safe operation, it is absolutely necessary for the user to follow the safety instructions and warning notes written in this user manual.

In order to install, operate, and maintain the lighting fixture safely and correctly we suggest that the installation and operation be carried out by qualified technicians and these instructions be carefully followed.

	CAUTION! HIGH VOLTAGE. RISK OF SEVERE OR FATAL ELECTRIC SHOCK
---	---

	CAUTION! ALWAYS DISCONNECT MAINS SUPPLY BEFORE REMOVING ANY FIXTURE COVERS
---	--

	CAUTION! NEVER LOOK DIRECTLY INTO THE LIGHT SOURCE. SENSITIVE PERSONS MAY SUFFER AN EPILEPTIC SHOCK
--	---

	CAUTION! NEVER TOUCH THE DEVICE DURING OPERATION! COVERS MAY BE HOT
---	---

CAUTION!	
	Warning: Changes or modifications to this unit not expressly approved by the party responsible for compliance could void the user's authority to operate the equipment.
	NOTE: This equipment has been tested and found to comply with the limits for a Class A digital device, pursuant to Part 15 of the FCC Rules. These limits are designed to provide reasonable protection against harmful interference when the equipment is operated in a commercial environment. This equipment generates, uses and can radiate radio frequency energy and, if not installed and used in accordance with the instruction manual, may cause harmful interference to radio communications. Operation of this equipment in a residential area is likely to cause harmful interference in which case the user will be required to correct the interference at his own expense.

Important:



Damage caused by the disregard of this user manual is not subject to warranty. The dealer and manufacturer will not accept liability for any resulting defects or problems.

- If the device has been exposed to temperature changes due to environmental conditions, do not power on immediately. The resulting condensation could damage the device. Leave the device powered off until it has reached room temperature.
- Ensure the sealing rubber covers of oower CON and XLR connectors are fitted properly when the device is not in use, to avoid water ingress.

- This device falls under protection-class I. Therefore, it is essential that the device be earthed.
- If either lenses or display are damaged (damage may include cracks or gashes in the material) they must be replaced.
- Electrical connections, such as replacing the power plug, must be performed by a qualified person.
- Make sure that the available voltage is not higher than that which is stated at the end of this manual.
- Make sure the power cord is never crushed or damaged by sharp edges. If this should be the case, replacement of the cable must be done by an authorized dealer.
- If the external flexible power cord of this device is damaged, it shall be exclusively replaced by the manufacturer or their service agent or a similar qualified person in order to avoid injury.
- When the device is not in use or before performing maintenance, always disconnect the device from the mains. Only handle the power cord from the plug. Never pull the plug out of a socket by tugging the power cord.
- When powered on for the first time, some smoke or smell may occur. This is caused by coating on metal parts when heated and is normal. If you are concerned, please contact your distributor.
- Do not focus the beam onto flammable surfaces. The minimum distance between the exiting lens of the device and the illuminated surface must be greater than 2 meter.

Please be aware that damage caused by any modifications to the device are not subject to warranty. Keep away from children and non-professionals.

1.2. GENERAL GUIDELINES

- This device is a lighting effect for professional use on stages, in discotheques, theatres, etc. the device was designed for indoor and outdoor use.
- This fixture is only allowed to be operated within the maximum alternating current as stated in the technical specifications in section 2 of this manual.
- Handle the device with care, avoid shaking or using force when installing or maintaining the device.
- If you use the quick lock cam when rigging the device, make sure the quick lock fasteners are located in the quick lock holes correctly and securely.
- Operate the device only after having familiarized yourself with its functions. Do not permit operation by persons not qualified for operating the device. Most damage is the result of unprofessional operation.
- Please use the original packaging if the device is to be transported.
- The applicable temperature for the device is between -20°C to 45°C. Do not use the device outside of this temperature range.
- The light source of this luminaire is not replaceable; when the light source reaches its end of life the whole luminaire shall be replaced.

For safety reasons, please be aware that all modifications to the device are forbidden.

If this device is operated in any way different to the ones described in this manual, the product

may suffer damage and the warranty becomes void. Furthermore, any other operation may lead to short-circuits, burns, electric shocks etc.

2. FEATURES

POWER SUPPLY

- AC100-240V~, 50/60Hz
- Power Consumption: 800W

LIGHT SOURCE

- LED: White LED500W, 8000± 500K Color Temperature
- Extremely long Life: >50,000H

MOVEMENT

- Pan movement: 540° /630° Optional (16 bit)
- Tilt movement: 270° (16 bit)
- Advanced moving system: fast, stable and quite, auto x-y repositioning

COLORS

- CMY + CTO color mixing, uniform, linear and speed can be adjustable
- 1 Color wheel: 7 dichroic filters + open, indexable, rainbow effect

GOBOS

- Rotating gobo wheel: 7 interchangeable, rotating, and indexable, gobo+open
- " Slot in & out" gobo wheel system
- Static gobo wheel: 11 + open, with different speed gobo shaking and gobo indexing

FEATURES

- 4 Control channel modes: 40/38/61/58 channels
- 2 Operation modes: DMX-512, Master / Slave mode
- Strobe effect with 1-25 flashes per second and pulse effect
- Rotating prism: 5-Facet Prism and Linear Prism, 16 prism Macros
- Animation wheel: can make special dynamic flame or water effect
- Focus: Motorized focus
- Stepless frost: 0%~100% linear change frost
- Stepless iris: 5%~100% linear change iris, pulse iris effect
- Dimmer: 0%~100% full range dimming

DISPLAY

- Advanced and convenient full –color LCD
- Locked automatically after standby for 15 seconds to prevent error; hold the button for 10 seconds to activate
- Pan and Tilt homing bypass: long press the center button to lock pan / tilt homing

- Can be changed 180° reverse to fit for different installation position

SOFTWARE

8 pre-installed programs available upon selection

Upgrades: fast and convenient through DMX cable with DMX-512 controller

Reset DMX address, remote lamp control, reset can all be done by the DMX controller

Running time of fixture on display for reference

OTHER SPEC

Input signal isolation: guarantees stable signal transmission without interference

Advanced RDM function

WEIGHT

Net weight: 40.23 kg

DMX CHANNEL CHART

%	1	2	3	4	5	6	7	8	9	10	11	12	13	14	15	16	17	18	19
%	Pan	Pan Fine	Tilt	Tilt Fine	Speed Pan (Tilt movement)	Strobe	Dimmer intensity	Chase Patterns	Chase Speed	Chase Fade	Zoom	Focus	Auto Focus	AutoFocus Fine	Color 1	C	M	Y	CTO
100%		16bit Pan Fine		16bit Tilt Fine	No function			Reserved	Slow to Fast Forward				15m						
75%					Blackout by all wheel changing	RANDOM STROBE		Chase 13		Fade Chase			10m						
50%					Blackout by movement	Pulse-effect in sequence		Chase 6	Stop (Speed=0)				7.5m						
25%					↑ Moving speed			Chase 1	Fast to Slow Backward				5m						
0%					Max			Open					Auto Focus Off						
%	20	21	22	23	24	25	26	27	28	29	30	31/33 35/37	32/34 36/38	39	40				
%	Rota. Gobo 1	Gobo Rotation 1	Fix Gobo 2	Animation wheel	Iris	Prism 1	Prism Rotation1	Prism 2	Prism Rotation2	Frost 1	Frost 2	Blade 1/2/3/4	Blade 1/2/3/4 Rotation	All Blade Rotation	Auto programs				
100%					Pulse opening slow to fast	5-Facet Prism		Linear Prism							Program 8				
75%					Pulse closing fast to slow										Program 1				
50%	Gobo Shake	Stop	Gobo Shake	Animation Wheel	↑ Moving speed	Open	Prism indexing	Open		↑ Moving speed	↑ Moving speed	Close		All Blade Rotation	Other motor reset				
25%												Open			Unused				
0%		GOGO INDEXING													Colors motor reset				
															Scan motor reset				
															All motor reset				
															Gobo correction On				
															Gobo correction Off				
															16K				
															2.4K				
															1.2K				
															Linear				
															Square Law				
															Silence fan control mode				
															Studio fan control mode				
															Stage fan control mode				
															Auto fan control mode				
															Display Invert On				
															Display Invert Off				
															Display On				
															Display Off				
															Unused				

3. FIXTURE OVERVIEW

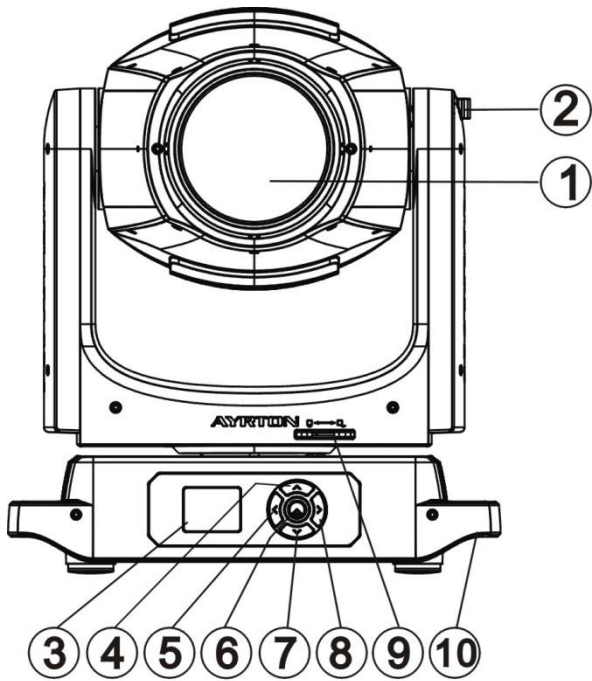

- 1) LED Assembly
- 2) Tilt Lock
- 3) Display
- 4) Up-button
- 5) Left-button
- 6) Center-button
- 7) Down-button
- 8) Right-button
- 9) Pan Lock
- 10) Handle

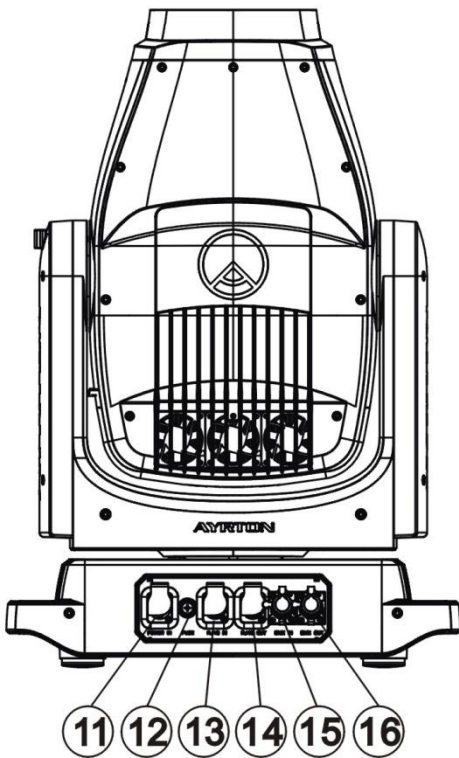

- 11) Power In
- 12) Fuse
- 13) RJ45 In
- 14) RJ45 Out
- 15) DMX In
- 16) DMX Out

4. DIMENSIONAL DRAWINGS

4.1. Fixture Dimension

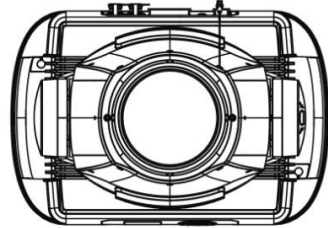
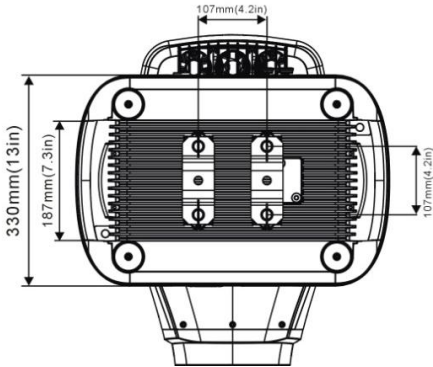
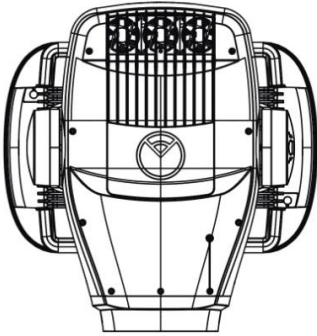
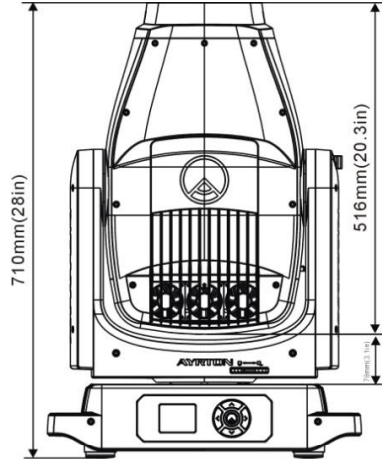
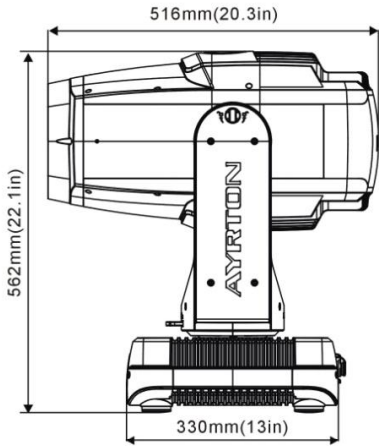
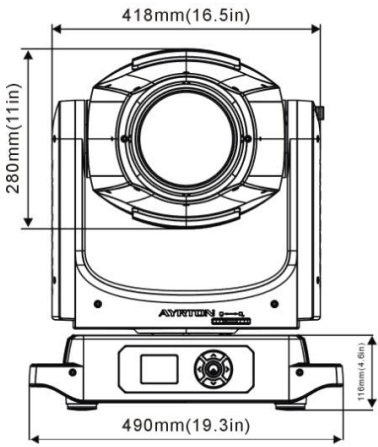

4.2. Gobo Filter Dimension

Rotating Gobo:

Black & White Gobo:

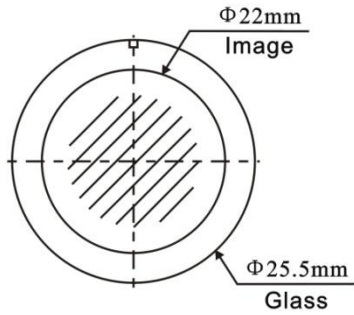

Color Gobo:

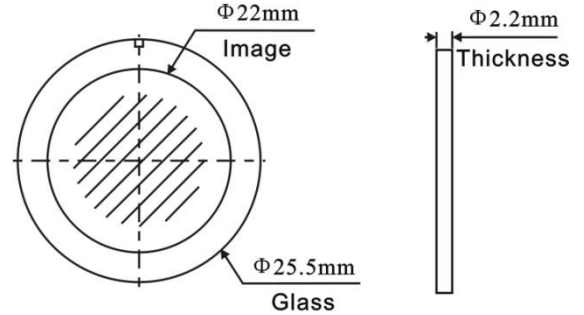

Fixed Gobo:

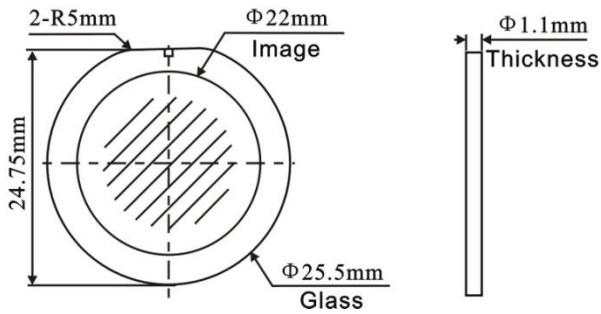

4.3. Color Filter Dimension

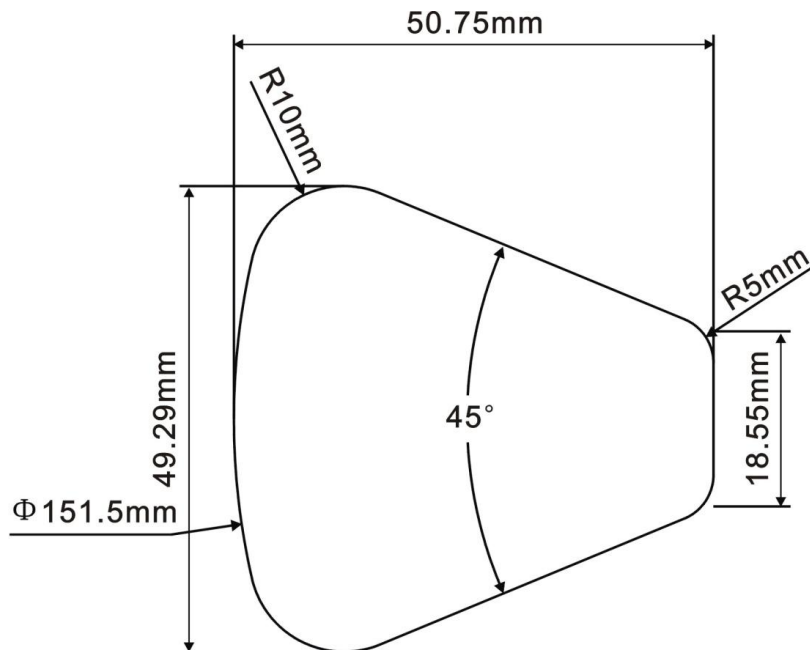

4.4. Animation Dimension

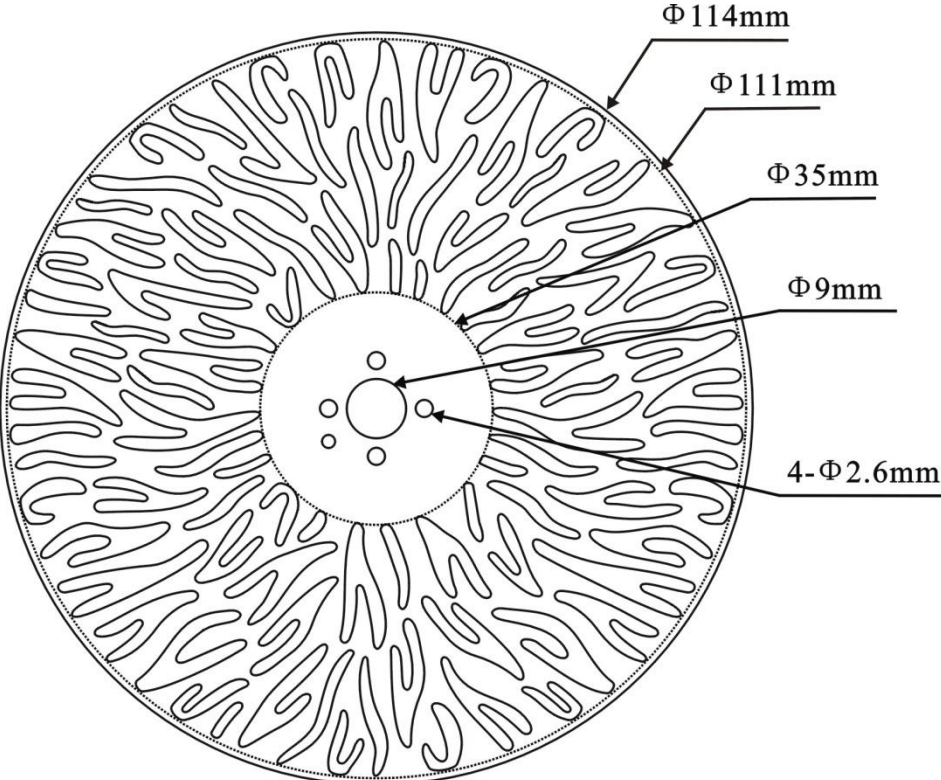

5. INSTALLATION INSTRUCTIONS

5.1. Rigging the device



CAUTION!

PLEASE CONSIDER THE RESPECTIVE NATIONAL NORMS DURING INSTALLATION. THE INSTALLATION MUST ONLY BE CARRIED OUT BY A QUALIFIED PERSON.

- The applicable temperature for the lighting is between -10°C to 45°C. Do not use the lighting under or above the temperature.
- The installation of the effect has to be built and constructed in a way that it can hold 10 times the weight for 1 hour without any harming deformation.
- The installation must always be secured with a secondary safety attachment, e. g. an appropriate safety rope.
- Never stand directly below the device when mounting, removing or servicing the fixture.
- The operator has to make sure the safety relating and machine technical installations are approved by an expert before taking the device into operation for the first time.
- These installations have to be approved by a skilled person once a year.
- Overhead mounting requires extensive experience, including amongst others calculating working load limits, installation material being used, and periodic safety inspection of all installation material and the device. If you lack these qualifications, do not attempt the installation yourself. Improper installation can result in bodily injury.

5.2. Rigging using the omega brackets

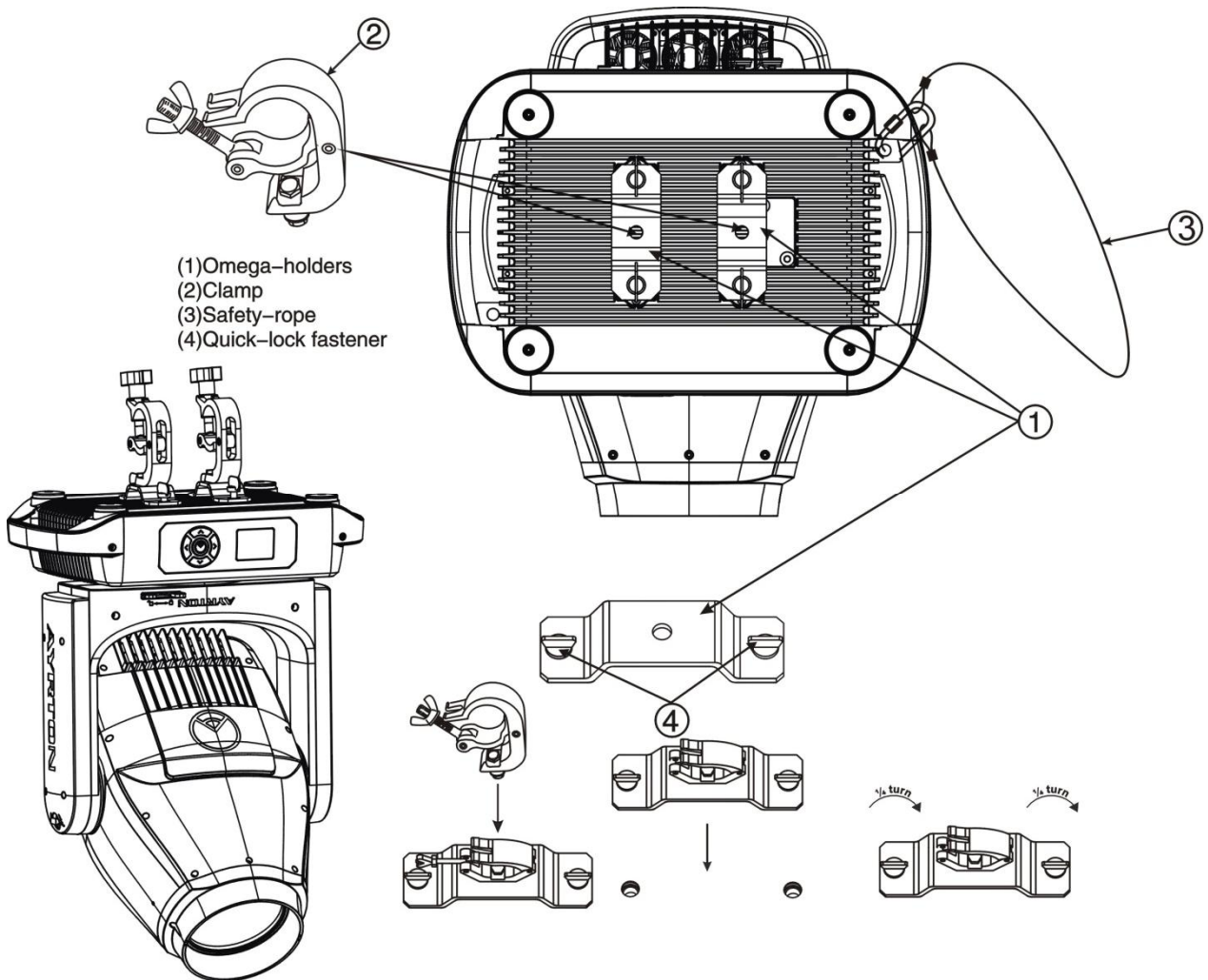

- Fix the clamp to the bracket by tightening the M12 nut and bolt to the bracket through the $\Phi 13$ hole in the middle of the bracket.
- Insert the quick-lock fasteners of the first Omega holder into the respective holes on the bottom of the device. Tighten the quick-lock fasteners fully clockwise.
- Install the second Omega holder.
- Pull the safety cable through the holes on the bottom of the base and over the trussing system or another suitable rigging point. Insert the end into the carabiner and tighten the safety screw.



Important:

This step is very important to ensure safe rigging of the fixture.

5.3. RIGGING DRAWINGS

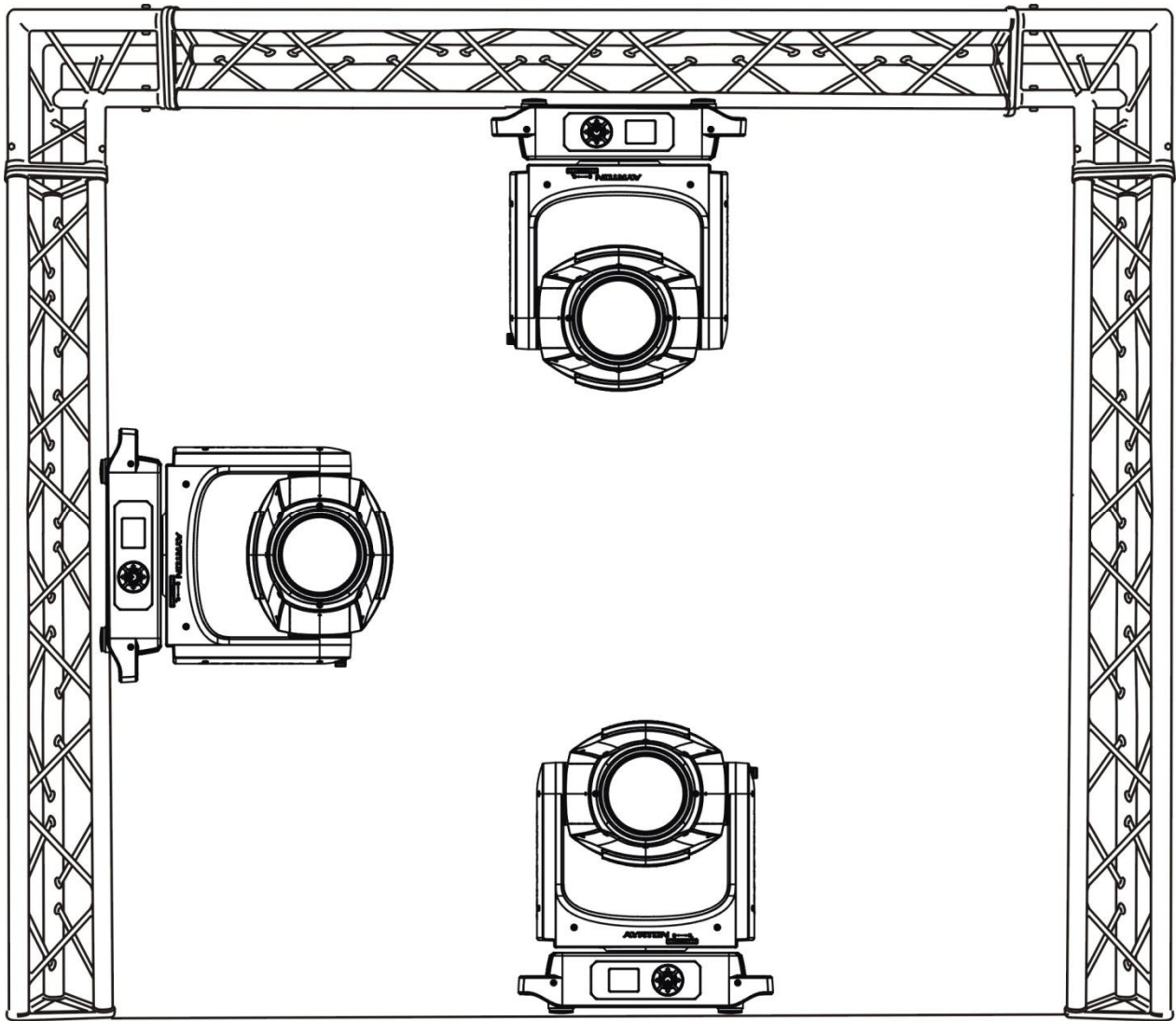

- Be sure this fixture is kept at least 0.1 m away from any flammable materials (decoration etc.).
- Always use and install the supplied safety cable as a safety measure to prevent accidental damage and/or injury in the event the clamp fails.



Important:

Overhead rigging requires extensive experience, including (but not limited to) calculating working load limits, specifying installation/ rigging materials, and periodic safety inspection of all installation material as well as the device. If you lack these qualifications, do not attempt the rigging of this device yourself. Improper installation/ rigging can result in serious bodily injury.

6. DMX-512 CONTROL CONNECTION

Connect the provided male side of the XLR cable to the female XLR output of your controller and the female side of the XLR cable to the male XLR input of the device. You can connect multiple devices together in a serial fashion. The cable needed should be two core, screened cable with XLR input and output connectors. Please refer to the diagram below.

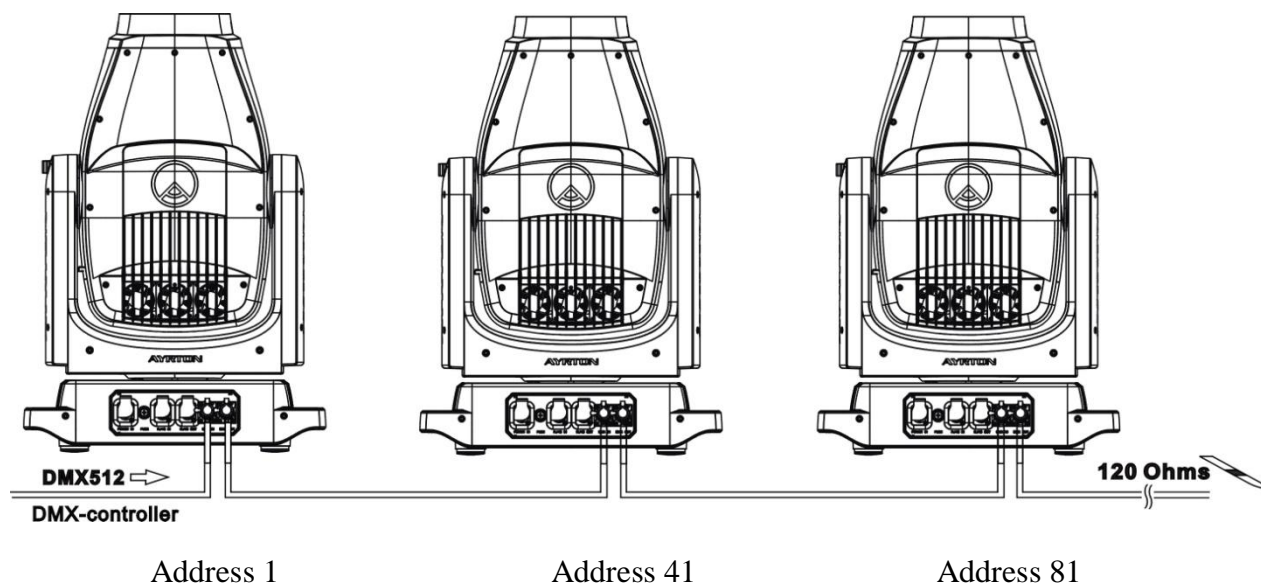
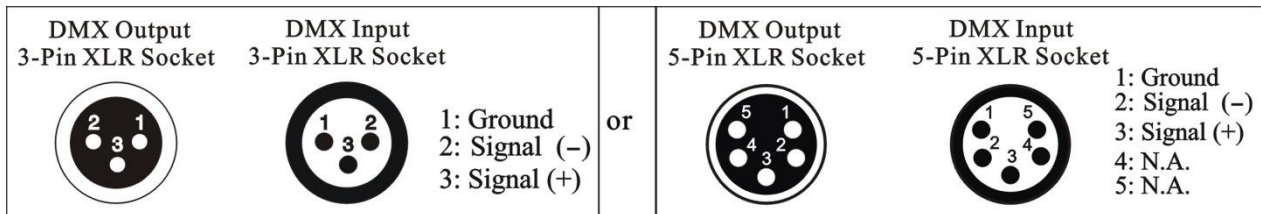

7. DMX-512 CONNECTION WITH DMX TERMINATOR

For installations where the DMX cable has to run over a long distance or is in an electrically noisy environment, such as in a discotheque, it is recommended to use a DMX terminator. This helps in preventing corruption of the digital control signal caused by electrical noise. The DMX terminator is an XLR plug with a 120 Ω resistor connected between pins 2 and 3, which is then plugged into the output (female) XLR socket of the last fixture in the chain. Please see illustrations below.

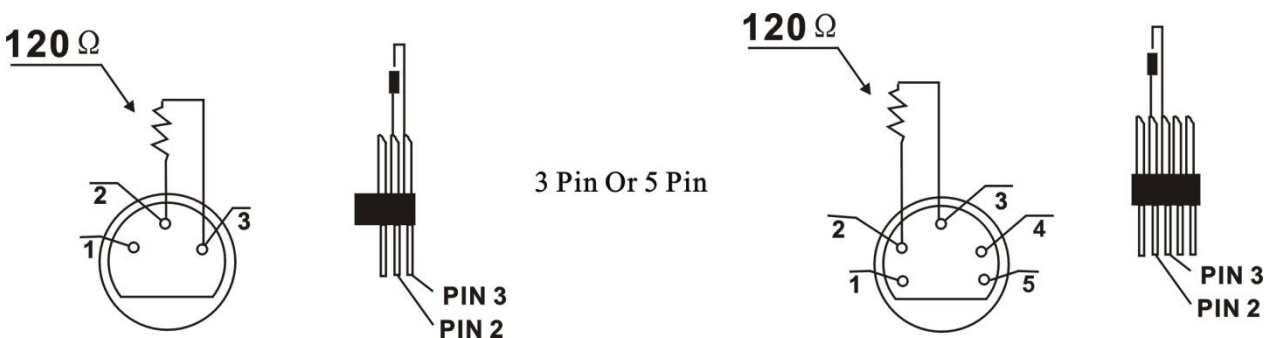

8. DEVICE DMX START ADDRESS SELECTION

All fixtures should be given a DMX starting address when using a DMX signal, so that the correct fixture responds to the correct control signals. This digital starting address is the channel number from which the fixture starts to "listen" to the digital control information sent out from the DMX controller. The allocation of this starting address is achieved by setting the correct address number on the display located on the base of the device.

You can set the same starting address for all fixtures or a group of fixtures, or set different addresses for each fixture individually.

If you set the same address on all devices, all the devices will start to "listen" to the same control signal from the same channel number. In other words, changing the settings of one channel will affect all the fixtures simultaneously.

If you set a different address, each unit will start to "listen" to the channel number you have set, based on the quantity of control channels of the unit. That means changing the settings of one channel will affect only the selected device.

In the case of the LED moving head, in 40 channel mode, you should set the starting address of the first unit to 1, the second unit to 41 (40 + 1), the third unit to 81 (40+ 41), and so on.

9. OPERATING INSTRUCTIONS OF THE INTERNAL DMX WIRELESS SYSTEM

9.1 Equipments:

DMX 512 controller, wireless transmitter, and the fixtures with wireless receiver.

9.2 Message from the LED indicator:

- 1) Rapid flashing red/Green: logging in to a transmitter.
- 2) Slow flashing Red/Green: Logged on a transmitter and the DMX line is idle (No DMX is connected to transmitter) .
- 3) Solid Green: Logged on to a transmitter and receiving DMX data.
- 4) Solid Red: Not logged on to a transmitter (free) .

9.3 WDMX in the menu of the fixture:

On a fixture installed with wireless system, in order to switch between wireless control system and traditional DMX control (with cable) , a new menu WDMX is added to the display board.

ON: (Activate WDMX)

- 1) When the fixture is on power, and the WDMX is activated to ON status, but did not connect to the controller and did not log in to the transmitter, the fixture will search for the DMX signal source. If the fixture is connected to the DMX controller it can be controlled by DMX controller; if it is log in to the wireless transmitter, it can be controlled by the Transmitter.
- 2) When the fixture is power off, and the WDMX is in ON status, if the fixture is connected

to DMX controller. After the fixture is power on, it can be controlled only by the DMX controller which connected. The fixture can log in the wireless transmitter, and receive only radio signal from transmitter, but not DMX from the transmitter.

OFF: (De-activate WDMX)

In this status, wireless system is not activated, so the fixture can not log in the transmitter.

REST: (reset WDMX memory)

Can remove the fixture from the connection with the transmitter, the fixture become free and ready to log in any transmitter.

9.4 Setup the wireless system:

- 1) Connect the transmitter with the DMX controller.
- 2) To make the fixture installed with wireless receiver log in to the transmitter.
 - a) Initially, the indicator on the receiver fixture should be in Solid red.
 - b) Press and hold the configuration button on transmitter for less than 3 seconds the red/green LEDs on the transmitter and the receiver fixture will flash rapidly for about 5~ 10 seconds while the system goes through its setup procedure.
 - c) Once the receiver fixture is logged in to the transmitter (T1), the fixture with wireless receiver will keep the memory, even if restart the power, this unit will log in the transmitter (T1) automatically.
- 3) Use the DMX 512 to control the fixture

9.5 Remove the receivers from transmitter (T1) and to log in to another transmitter (T2) :

Case 1: Remove a receiver:

- a) On the control board of the fixture, enter menu to activated the function of REST;
- b) The LED for wireless on the fixture should turn to Solid red; the receiver can log out from the transmitter (T1) ;
- c) press the configuration button on transmitter (T2) for less than 3 second, then the fixture will start to connect with the transmitter (T2) .

Case 2: Remove all receivers from a transmitter (T1) to log in to T2:





- a) Press and hold the configuration button on the T1 as least 5 seconds, can clear the connection with all the fixtures;
- b) All the red/green LEDs on the receiver fixtures will turn to Solid red to indicate that the receivers are unassigned and removed from the transmitter (T1) ;
- c) Press and hold the configuration button on the T2 less then less than 3 second, the fixtures will connect with the T2.



PS:

1. Please log the receivers out from the transmitter after every job, so that the receivers are in free un assigned state and ready to be assigned to a transmitter.
2. Do not connect the fixture which is under the communication of wireless system to the DMX controller, otherwise it will cause interference from the DMX controller.

10. DISPLAY

The Display offers several features: you can set the starting address, run the pre-programmed program or reset the device.

The main menu is accessed by double clicking  -button until the display starts flashing. Browse through the menu by pressing the  -button,  -button,  -button or  - button .

Press  for 2 seconds in order to select the desired menu or exit menu, double click  for confirm. After accessing the edit mode, the unit will automatically exit to the main menu after 15 seconds from the last button press.

When the unit is powered on, if no data signal is connected after 1 minute, then the display will switch off automatically.

Default settings shaded

Address	Address	DMX address:001-XXX		DMX address setting
Mode	User Mode	Stand Mode Basic Mode Extend Mode Ghibli Mode User Mode A User Mode B User Mode C		User's mode to change channel numbers
	Edit User ModeA :	Max channel PAN :		Preset User modes A,B,C :
Options	Status	No DMX Mode Pan Reverse Tilt Reverse Pan Degree Feedback Init PAN Init TILT Pan/Tilt Spd Hibernation Art-Net to DMX	Close/ Hold /Auto ON/OFF ON/OFF 630/540 ON/OFF ON/OFF ON/OFF Speed 1~ 4 OFF , 01M~99M ON/OFF	Auto run if no DMX Pan Reverse movement Tilt Reverse movement Pan Degree Select Movement Feedback Init PAN Init TILT Movement Speed Stand by Mode Art-Net to DMX
	Service PIN	Service PIN Set Ip Cross Load SW Clr LED Time	Password=XXX xxx.xxx.xxx.xxx ON/OFF ON/OFF	Service Password"=050" Set Ip Cross Load SW Clr LED Time

	Fans Control	Auto Stage Studio Silence		Fans Speed select
	Disp.Setting	Shutoff Time Flip Display Key Lock DispFlash	02~60m 05m ON/OFF ON/OFF ON/OFF	Display shutoff time Reverse 180 degree Key Lock DispFlash
	Signal Select	DMX WDMX Art—Net sACN		DMX WDMX Art-Net sACN
	Temp. C/F	Celsius Fahrenheit		Temperature switch between °C/°F
	Initial Pos.	PAN =XXX		Initial effect position
	Wireless DMX	Activate WDMX Act&Data Out Rest WDMX		Activate WDMX Act&Data Out Rest WDMX
	Dim Curve	Square Law Linear		Dim Curve
	Refresh Select	1.2K 2.4K 16K		Refresh Select
	Gobo Correction	ON/OFF		Gobo Correction
	Trigger	DMX Value Disp. Set To Slave Auto Program	PAN..... Slave1,Slave2,Slave3 Master / Alone	DMX Value Disp. Set To Slave Auto Program
	ResetDefault	ON/OFF		Restore factory set.
Info	Time Info.	Current Time Ttl Life Hrs Last Run Hrs LED Hours Timer PIN Clr Last Run		XXXX(Hours) XXXX(Hours) XXXX(Hours) XXXX(Hours) Password=XXX ON/OFF
	Temp. Info	XXX°C/°F		Temp. Infomation
	Head Humidity	x%		Head Humidity
	Fan Info.	xxxxRPM		Fan information
	Software Ver	V1.0.....		Software version
	Network	IP,Mask,Mac		Network
Test	Home	All Pan&Tilt Color Gobo Other		Reset All Reset Pan&Tilt Reset Color Reset Gobo Reset Others
	Test Channel	PAN		Test function

	Manual Ctrl.	PAN =XXX :		Fine adjustment of the lamp
	Calibration	-Password- PAN :		Password "050" Calbrate and adjust the effects to standard/right position
Preset	Select Prog.	Prog. Part 1 = Program 1 ~ 10 Program 1 Prog. Part 2 = Program 1 ~ 10 Program 2 Prog. Part 3 = Program 1 ~ 10 Program 3		Select programs to be run
	Edit Prog.	Program 1 : Program 10	Program Test Step 01=SCxxx Step 64=SCxxx	Testing program Program in loop Save and exit
	Edit Scenes	Edit Scene 001 ~ Edit Scene 250	Pan,Tilt,..... --Fade Time-- --Secne Time-- Input By Outside	Save and automatically return manual scenes edit
	Scenes Input	XX~XX		Scenes Input

10.1. Address

10.1.1. Set DMX Address

With this function, you can adjust the desired DMX-address via the Display.

1. Double clicking center button to access main menu.
2. Tap the <Up/Down> button until " Address" is displayed.
3. Double clicking center button, the display will show " Set DMX Address" .
4. Tap the <Up/Down> button, the display will show " A001~AXXX" .
5. Double click the center button to confirm or long press the center button to return to the main menu.

10.2.Mode

10.2.1. User Mode

With this function, you can create user defined channel orders.

1. Double clicking center button to access main menu; Tap the <Up/Down> button until " Mode" is displayed. Double clicking center button to enter.
2. Press <Up/Down>, the display will show " User Mode" .
3. Double clicking center button to enter.
4. When in " Extend Mode", Press <Up/Down> button to select " Basic Mode", " Stand Mode", " Ghibli Mode", " User Mode A", " User Mode B" and " User Mode C" .
5. Double click the center button to confirm or long press the center button to return to the main menu.

10.2.2. Edit User Mode

With this function, you can adjust the rest user defined channel order.

1. Double clicking center button to access main menu; Tap the <Up/Down> button until " Mode" is displayed. Double clicking center button to enter.
2. Press <Up/Down>, the display will show " Edit User Mode" .

3. Double clicking center button to enter.
4. Set up " Max Channel=xxx" and select channel value.
5. Set up " Mode B" and " Mode C" by the same way.
6. Double click the center button to confirm or long press the center button to return to the main menu.

10.3.Options

10.3.1. Status

No DMX Status

With this function, when the drive is not DMX signal, it runs automatism, close, hold and music, the default is hold.

1. Double clicking center button to access main menu.
2. Tap the <Up/Down> button until " Options" is displayed.
3. Double clicking center button to access " Options", Tap the <Up/Down> button to select " Status" .
4. Double clicking center button to access " Status" menu, Tap the <Up/Down> button to select " No DMX Status" .
5. Double clicking center button to access " No DMX Status", The display will show " Hold", Tap the <Up/Down> button to select " Close", " Auto" .
6. Double click the center button to confirm or long press the center button to return to the main menu.

Pan Reverse

With this function you can reverse the Pan-movement.

1. Double clicking center button to access main menu.
2. Tap the <Up/Down> button until " Options" is displayed.
3. Double clicking center button to access " Options", Tap the <Up/Down> button to select " Status" .
4. Double clicking center button to access " Status" menu, Tap the <Up/Down> button to select " Pan Reverse" .
5. Double clicking center button to access " Pan Reverse", The display will show " OFF", Tap the <Up/Down> button to select " NO" .
6. Double click the center button to confirm or long press the center button to return to the main menu.

Tilt Reverse

With this function you can reverse the Tilt-movement.

1. Double clicking center button to access main menu.
2. Tap the <Up/Down> button until " Options" is displayed.
3. Double clicking center button to access " Options", Tap the <Up/Down> button to select " Status" .
4. Double clicking center button to access " Status" menu, Tap the <Up/Down> button to select " Tilt Reverse" .
5. Double clicking center button to access " Tilt Reverse", The display will show " OFF", Tap the <Up/Down> button to select " NO" .
6. Double click the center button to confirm or long press the center button to return to the

main menu.

Pan Degree

With this function, you can select pan degree for 630 or 540.

1. Double clicking center button to access main menu.
2. Tap the <Up/Down> button until " Options" is displayed.
3. Double clicking center button to access" Options", Tap the <Up/Down> button to select " Status" .
4. Double clicking center button to access" Status" menu, Tap the <Up/Down> button to select" Pan Degree" .
5. Double clicking center button to access" Pan Degree", The display will show " 540", Tap the <Up/Down> button to select " 630" .
6. Double click the center button to confirm or long press the center button to return to the main menu.

Feedback

With this function, you can feedback switch of pan movement or tilt movement.

1. Double clicking center button to access main menu.
2. Tap the <Up/Down> button until " Options" is displayed.
3. Double clicking center button to access" Options", Tap the <Up/Down> button to select " Status" .
4. Double clicking center button to access" Status" menu, Tap the <Up/Down> button to select" Feedback" .
5. Double clicking center button to access" Feedback", The display will show " ON", Tap the <Up/Down> button to select " OFF" .
6. Double click the center button to confirm or long press the center button to return to the main menu.

Init PAN

With this function, you can feedback switch of pan movement or tilt movement.

1. Double clicking center button to access main menu.
2. Tap the <Up/Down> button until " Options" is displayed.
3. Double clicking center button to access" Options", Tap the <Up/Down> button to select " Status" .
4. Double clicking center button to access" Status" menu, Tap the <Up/Down> button to select" Init PAN" .
5. Double clicking center button to access" Init PAN", The display will show " ON", Tap the <Up/Down> button to select " OFF" .
6. Double click the center button to confirm or long press the center button to return to the main menu.

Init TILT

With this function, you can feedback switch of pan movement or tilt movement.

1. Double clicking center button to access main menu.
2. Tap the <Up/Down> button until " Options" is displayed.
3. Double clicking center button to access" Options", Tap the <Up/Down> button to select " Status" .

4. Double clicking center button to access " Status" menu, Tap the <Up/Down> button to select " Init TILT" .
5. Double clicking center button to access " Init TILT", The display will show " ON", Tap the <Up/Down> button to select " OFF" .
6. Double click the center button to confirm or long press the center button to return to the main menu.

Pan/Tilt Spd

With this function, you can select scan mode from 1 to 4.

1. Double clicking center button to access main menu.
2. Tap the <Up/Down> button until " Options" is displayed.
3. Double clicking center button to access " Options", Tap the <Up/Down> button to select " Status" .
4. Double clicking center button to access " Status" menu, Tap the <Up/Down> button to select " Pan/Tilt Spd" .
5. Double clicking center button to access " Pan/Tilt Spd", The display will show " Speed 1", Tap the <Up/Down> button to select " Speed 1", " Speed 2", " Speed 3", " Speed 4" .
6. Double click the center button to confirm or long press the center button to return to the main menu.

Hibernation: Standby mode

The device and step motors will be power off if the fixture stay without DMX signal for 15 mins (Factory default). And the fixture will be reset before working once it receive DMX signal again.

1. Double clicking center button to access main menu.
2. Tap the <Up/Down> button until " Options" is displayed.
3. Double clicking center button to access " Options", Tap the <Up/Down> button to select " Status" .
4. Double clicking center button to access " Status" menu, Tap the <Up/Down> button to select " Hibernation" .
5. Double clicking center button to access " Hibernation", The display will show " OFF", Tap the <Up/Down> button to select " 01M", " 02M" . . . " 99M" .
6. Double click the center button to confirm or long press the center button to return to the main menu.

Art-Net to DMX

With this function, you can select Art-Net to DMX.

1. Double clicking center button to access main menu.
2. Tap the <Up/Down> button until " Options" is displayed.
3. Double clicking center button to access " Options", Tap the <Up/Down> button to select " Status" .
4. Double clicking center button to access " Status" menu, Tap the <Up/Down> button to select " Art-Net to DMX" .
5. Double clicking center button to access " Art-Net to DMX", The display will show " OFF", Tap the <Up/Down> button to select " ON" .
6. Double click the center button to confirm or long press the center button to return to the

main menu.

10.3.2. Service PIN

Password

The Password for this function is " 050" .

Set IP

1. Double clicking center button to access main menu.
2. Tap the <Up/Down> button until " Options" is displayed.
3. Double clicking center button to access " Options", Tap the <Up/Down> button to select " Service PIN" .
4. Double clicking center button to access " Service PIN" menu, Tap the <Up/Down> button to select " Set IP" .
5. Double clicking center button to access " Set IP ", The display will show " XXX.XXX.XXX.XXX" .
6. Double click the center button to confirm or long press the center button to return to the main menu.

Cross Load SW

1. Double clicking center button to access main menu.
2. Tap the <Up/Down> button until " Options" is displayed.
3. Double clicking center button to access " Options", Tap the <Up/Down> button to select " Service PIN" .
4. Double clicking center button to access " Service PIN" menu, Tap the <Up/Down> button to select " Cross Load SW" .
5. Double clicking center button to access " Cross Load SW", The display will show " OFF", Tap the <Up/Down> button to select " ON" .
6. Double click the center button to confirm or long press the center button to return to the main menu.

Clr LED Timer

1. Double clicking center button to access main menu.
2. Tap the <Up/Down> button until " Options" is displayed.
3. Double clicking center button to access " Options", Tap the <Up/Down> button to select " Service PIN" .
4. Double clicking center button to access " Service PIN" menu, Tap the <Up/Down> button to select " Clr LED Timer" .
5. Double clicking center button to access " Clr LED Timer", The display will show " OFF", Tap the <Up/Down> button to select " ON" .
6. Double click the center button to confirm or long press the center button to return to the main menu.

10.3.3. Fans Control

With this function you can set the speed of the running fans. The selections have Auto、Stage and Studio.

1. Double clicking center button to access main menu.
2. Tap the <Up/Down> button until " Options" is displayed.

3. Double clicking center button to access " Options", Tap the <Up/Down> button to select " Fans Control" .
4. Double clicking center button to access " Fans Control" menu, Tap the <Up/Down> button to select " Head Control" .
5. Double clicking center button to access " Head Control", The display will show " Auto", Tap the <Up/Down> button to select " Stage" , " Studio" , " Silence" .
6. Double click the center button to confirm or long press the center button to return to the main menu.

10.3.4. Disp. Setting

Shut off Time

With this function you can shut off the LCD display after 2 to 60 minutes. The default is 5 minutes.

1. Double clicking center button to access main menu.
2. Tap the <Up/Down> button until " Options" is displayed.
3. Double clicking center button to access " Options", Tap the <Up/Down> button to select " Display Setting" .
4. Double clicking center button to access " Display Setting" menu, Tap the <Up/Down> button to select " Shut off Time" .
5. Double clicking center button to access " Shut off Time", The display will show " 05m", Tap the <Up/Down> button to select " 02~60m" .
6. Double click the center button to confirm or long press the center button to return to the main menu.

Flip Display

With this function you can rotate the display by 180°.

1. Double clicking center button to access main menu.
2. Tap the <Up/Down> button until " Options" is displayed.
3. Double clicking center button to access " Options", Tap the <Up/Down> button to select " Display Setting" .
4. Double clicking center button to access " Display Setting" menu, Tap the <Up/Down> button to select " Flip Display" .
5. Double clicking center button to access " Flip Display", The display will show " OFF", Tap the <Up/Down> button to select " ON" .
6. Double click the center button to confirm or long press the center button to return to the main menu.

Key Lock

With this function you can activate the automatic key lock function. If this function is activated, the keys will be locked automatically after exiting the edit mode for 15 seconds. Keeping press the <MODE/ESC> key for 3seconds if you do not need this function.

1. Double clicking center button to access main menu.
2. Tap the <Up/Down> button until " Options" is displayed.
3. Double clicking center button to access " Options", Tap the <Up/Down> button to select " Display Setting" .
4. Double clicking center button to access " Display Setting" menu, Tap the <Up/Down>

- button to select " Key Lock" .
5. Double clicking center button to access " Key Lock", The display will show " OFF", Tap the <Up/Down> button to select " ON" .
 6. Double click the center button to confirm or long press the center button to return to the main menu.

DispFlash

With this function you can the entire display to be flipped by 180° to allow for better view when the fixture is hung from truss or a ceiling. This function is disabled as default.

1. Double clicking center button to access main menu.
2. Tap the <Up/Down> button until " Options" is displayed.
3. Double clicking center button to access " Options", Tap the <Up/Down> button to select " Display Setting" .
4. Double clicking center button to access " Display Setting" menu, Tap the <Up/Down> button to select " DispFlash" .
5. Double clicking center button to access " DispFlash", The display will show " OFF", Tap the <Up/Down> button to select " ON" .
6. Double click the center button to confirm or long press the center button to return to the main menu.

10.3.5. Signal Select

1. Double clicking center button to access main menu.
2. Tap the <Up/Down> button until " Options" is displayed.
3. Double clicking center button to access " Options", Tap the <Up/Down> button to select " Signal Select" .
4. Double clicking center button to access " Signal Select", The display will show " DMX", Tap the <Up/Down> button to select " DMX", " WDMX", " Art--Net", " sACN" .
5. Double click the center button to confirm or long press the center button to return to the main menu.

10.3.6. Temperature C/F

With this function you can display the temperature in Celsius or Fahrenheit.

1. Double clicking center button to access main menu.
2. Tap the <Up/Down> button until " Options" is displayed.
3. Double clicking center button to access " Options", Tap the <Up/Down> button to select " Temperature C/ F" .
4. Double clicking center button to access " Temperature C/ F", The display will show " Fahrenheit", Tap the <Up/Down> button to select " Celsius" .
5. Double click the center button to confirm or long press the center button to return to the main menu.

10.3.7. Initial Pos.

With this function you can display initial effect position.

1. Double clicking center button to access main menu.
2. Tap the <Up/Down> button until " Options" is displayed.
3. Double clicking center button to access " Options", Tap the <Up/Down> button to select " Initial Pos. " .

4. Double clicking center button to access " Initial Pos. ", The display will show " PAN=XXX " .
5. Double click the center button to confirm or long press the center button to return to the main menu.

10.3.8. Wireless DMX

From factory, this projector is prepared for wireless data transmission (W-DMX) . If you wish to de-activate W-DMX control, you can select the function" De-activate WDMX" by turning the encoder. With the function" rest" , you can log out the projector from the wireless sender.

1. Double clicking center button to access main menu.
2. Tap the <Up/Down> button until" Options" is displayed.
3. Double clicking center button to access" Options", Tap the <Up/Down> button to select " Wireless DMX" .
4. Double clicking center button to access" Wireless DMX", The display will show " Activate WDMX", Tap the <Up/Down> button to select" Act&Data Out" , " Rest WDMX" .
5. Double click the center button to confirm or long press the center button to return to the main menu.

10.3.9. Dim Curve

1. Double clicking center button to access main menu.
2. Tap the <Up/Down> button until" Options" is displayed.
3. Double clicking center button to access" Options", Tap the <Up/Down> button to select " Dim Curve" .
4. Double clicking center button to access" Dim Curve", The display will show " Square Law", Tap the <Up/Down> button to select" Linear" .
5. Double click the center button to confirm or long press the center button to return to the main menu.

10.3.10. Refresh Select

With this function you can select the refresh.

1. Double clicking center button to access main menu.
2. Tap the <Up/Down> button until" Options" is displayed.
3. Double clicking center button to access" Options", Tap the <Up/Down> button to select " Refresh Select" .
4. Double clicking center button to access" Refresh Select", The display will show " 1.2K", Tap the <Up/Down> button to select" 2.4K" , " 16K" .
5. Double click the center button to confirm or long press the center button to return to the main menu.

10.3.11. Gobo Correction

With this function you can select the CTB.

1. Double clicking center button to access main menu.
2. Tap the <Up/Down> button until" Options" is displayed.
3. Double clicking center button to access" Options", Tap the <Up/Down> button to select " Gobo Correction" .
4. Double clicking center button to access" Gobo Correction", The display will show

- " ON", Tap the <Up/Down> button to select " OFF" .
5. Double click the center button to confirm or long press the center button to return to the main menu.

10.3.12. Trigger

DMX Value Disp.

With this function you can display the DMX 512 value of each channel. The display automatically shows the channel with a value changing.

1. Double clicking center button to access main menu.
2. Tap the <Up/Down> button until " Options" is displayed.
3. Double clicking center button to access " Options", Tap the <Up/Down> button to select " Trigger" .
4. Double clicking center button to access " Trigger" menu, Tap the <Up/Down> button to select " DMX Value Disp" .
5. Double clicking center button to access " DMX Value Disp", The display will show " PAN=....." .
6. Double click the center button to confirm or long press the center button to return to the main menu.

Set To Slave

With this function, you can define the device as slave.

1. Double clicking center button to access main menu.
2. Tap the <Up/Down> button until " Options" is displayed.
3. Double clicking center button to access " Options", Tap the <Up/Down> button to select " Trigger" .
4. Double clicking center button to access " Trigger" menu, Tap the <Up/Down> button to select " Set To Slave" .
5. Double clicking center button to access " Set To Slave", The display will show " Slave1" , " Slave2" , " Slave3" .
6. Double click the center button to confirm or long press the center button to return to the main menu.

Auto Program

With this function, you can run the internal program. You can select the desired program under " **Select program**" . You can set the number of steps under " **Edit program**" . You can edit the individual scenes under " **Edit scenes**" . With this function, you can run the individual scenes either automatically, i. e. with the adjusted Step-Time.

1. Double clicking center button to access main menu.
2. Tap the <Up/Down> button until " Options" is displayed.
3. Double clicking center button to access " Options", Tap the <Up/Down> button to select " Trigger" .
4. Double clicking center button to access " Trigger" menu, Tap the <Up/Down> button to select " Auto Program" .
5. Double clicking center button to access " Auto Program", The display will show " Master" , " Alone" .
6. Double click the center button to confirm or long press the center button to return to the

main menu.

10.3.13. Reset Default

With this function, you can select restore factory set for ON or OFF, the default is OFF.

1. Double clicking center button to access main menu.
2. Tap the <Up/Down> button until " Options" is displayed.
3. Double clicking center button to access" Options", Tap the <Up/Down> button to select " Reset Default" .
4. Double clicking center button to access" Reset Default" menu, The display will show " OFF", Tap the <Up/Down> button to select " ON" .
5. Double click the center button to confirm or long press the center button to return to the main menu.

10.4. Info

10.4.1. Time Info.

Current Time

With this function, you can display the temporary running time of the device from the last power on. The display shows " XXXX" , " XXXX" stands for the number of hours. The counter is reset after turning the device off.

1. Double clicking center button to access main menu.
2. Tap the <Up/Down> button until " Info" is displayed.
3. Double clicking center button to access" Info", Tap the <Up/Down> button to select " Time Info." .
4. Double clicking center button to access" Time Info.", Tap the <Up/Down> button to select" Current Time" .
5. Double clicking center button to access" Current Time", The display will show " XXXX (Hours)" .
6. Double click the center button to confirm or long press the center button to return to the main menu.

Ttl Life Hrs

With this function, you can display the running time of the device. The display shows " XXXX" , " XXXX" stands for the number of hours.

1. Double clicking center button to access main menu.
2. Tap the <Up/Down> button until " Info" is displayed.
3. Double clicking center button to access" Info", Tap the <Up/Down> button to select " Time Info." .
4. Double clicking center button to access" Time Info.", Tap the <Up/Down> button to select " Ttl Life Hrs" .
5. Double clicking center button to access" Ttl Life Hrs", The display will show " XXXX (Hours)" .
6. Double click the center button to confirm or long press the center button to return to the main menu.

Last Run Hrs

With this function, you can display last the running time of the device. The display shows

" XXXX" , " XXXX" stands for the number of hours.

1. Double clicking center button to access main menu.
2. Tap the <Up/Down> button until " Info" is displayed.
3. Double clicking center button to access " Info", Tap the <Up/Down> button to select " Time Info." .
4. Double clicking center button to access " Time Info.", Tap the <Up/Down> button to select " Last Run Hrs" .
5. Double clicking center button to access " Last Run Hrs", The display will show " XXXX (Hours)" .
6. Double click the center button to confirm or long press the center button to return to the main menu.

LED Hours

With this function, you can display the time of LED. The display shows " XXXX"; " XXXX" stands for the time of LED.

1. Double clicking center button to access main menu.
2. Tap the <Up/Down> button until " Info" is displayed.
3. Double clicking center button to access " Info", Tap the <Up/Down> button to select " Time Info." .
4. Double clicking center button to access " Time Info.", Tap the <Up/Down> button to select " LED Hours" .
5. Double clicking center button to access " LED Hours", The display will show " XXXX (Hours)" .
6. Double click the center button to confirm or long press the center button to return to the main menu.

Timer PIN

With this function, you can display the timer password.

1. Double clicking center button to access main menu.
2. Tap the <Up/Down> button until " Info" is displayed.
3. Double clicking center button to access " Info", Tap the <Up/Down> button to select " Time Info." .
4. Double clicking center button to access " Time Info.", Tap the <Up/Down> button to select " Timer PIN" .
5. Double clicking center button to access " Timer PIN", The display will show " Password=038" .
6. Double click the center button to confirm or long press the center button to return to the main menu.

Clr Last Run

With this function, you can clear last run time of the fixture. The display shows " ON" or " OFF", Press " Enter" to confirm.

1. Double clicking center button to access main menu.
2. Tap the <Up/Down> button until " Info" is displayed.
3. Double clicking center button to access " Info", Tap the <Up/Down> button to select " Time Info." .

4. Double clicking center button to access " Time Info.", Tap the <Up/Down> button to select " Clear Last Run" .
5. Double clicking center button to access " Clear Last Run", The display will show " OFF", Tap the <Up/Down> button to select " ON" .
6. Double click the center button to confirm or long press the center button to return to the main menu.

10.4.2. Temp. Info

With this function you can display the temperature on the display board of the base (near CMY-filter) in Celsius.

1. Double clicking center button to access main menu.
2. Tap the <Up/Down> button until " Info" is displayed.
3. Double clicking center button to access " Info", Tap the <Up/Down> button to select " Temp Info" .
4. Double clicking center button to access " Time Info.", The display will show " XXX °C/ °F" .
5. Double click the center button to confirm or long press the center button to return to the main menu.

10.4.3. Head Humidity

With this function you can display the humidity on the display board.

1. Double clicking center button to access main menu.
2. Tap the <Up/Down> button until " Info" is displayed.
3. Double clicking center button to access " Info", Tap the <Up/Down> button to select " Head Humidity" .
4. Double clicking center button to access " Head Humidity", The display will show " x%" .
5. Double click the center button to confirm or long press the center button to return to the main menu.

10.4.4. Fan Info.

With this function, you can display the software version of the device.

1. Double clicking center button to access main menu.
2. Tap the <Up/Down> button until " Info" is displayed.
3. Double clicking center button to access " Info", Tap the <Up/Down> button to select " Fan Info." .
4. Double clicking center button to access " Fan Info.", The display will show " xxxxRPM" .
5. Double click the center button to confirm or long press the center button to return to the main menu.

10.4.5. Software Ver

With this function, you can display the software version of the device.

1. Double clicking center button to access main menu.
2. Tap the <Up/Down> button until " Info" is displayed.
3. Double clicking center button to access " Info", Tap the <Up/Down> button to select " Software Ver" .

4. Double clicking center button to access " Software Ver", The display will show " Ver x.x.x" .
5. Double click the center button to confirm or long press the center button to return to the main menu.

10.4.6. Network

1. Double clicking center button to access main menu.
2. Tap the <Up/Down> button until " Info" is displayed.
3. Double clicking center button to access " Info", Tap the <Up/Down> button to select " Network" .
4. Double clicking center button to access " Network", The display will show " IP" , Turn the center button to select " Mask", " Mac" .
5. Double click the center button to confirm or long press the center button to return to the main menu.

10.5. Test

10.5.1. Home

With this function you can reset the device via the Control Board. You can select the different reset functions by turning the encoder.

1. Double clicking center button to access main menu.
2. Tap the <Up/Down> button until " Test" is displayed.
3. Double clicking center button to access " Test", Tap the <Up/Down> button to select " Home" .
4. Double clicking center button to access " Home", The display will show " All" , Tap the <Up/Down> button to select " All", " Pan&Tilt", " Color", " Gobo", " Other" .
5. Double click the center button to confirm or long press the center button to return to the main menu.

10.5.2. Test Channel

With this function you can test each channel's function to ensure correct operation.

1. Double clicking center button to access main menu.
2. Tap the <Up/Down> button until " Test" is displayed.
3. Double clicking center button to access " Test", Tap the <Up/Down> button to select " Test Channel" .
4. Double clicking center button to access " Test Channel", The display will show " Pan", Tap the <Up/Down> button to select other channel.
5. Double click the center button to confirm or long press the center button to return to the main menu.

10.5.3. Manual Control

When set to Manual Mode, fixture will be back to factory settings. If want to adjust brightness, can adjust by shutter and dimming channel, channel value is 0-255. Other functions can be set according to user's real need.

1. Double clicking center button to access main menu.
2. Tap the <Up/Down> button until " Test" is displayed.
3. Double clicking center button to access " Test", Tap the <Up/Down> button to select

- " Manual control" .
- 4. Double clicking center button to access" Manual control", The display will show " PAN=XXX" .
- 5. Double click the center button to confirm or long press the center button to return to the main menu.

10.5.4. Calibration

With this function, you can calibrate and adjust the effect wheels to their correct positions. The password of calibrate values is 050.

1. Double clicking center button to access main menu.
2. Tap the <Up/Down> button until" Test" is displayed.
3. Double clicking center button to access" Test", Tap the <Up/Down> button to select " Calibration" .
4. Double clicking center button to access" Calibration", The display will show " Password=050" .
5. Double click the center button to confirm or long press the center button to return to the main menu.

10.6. Preset

1. Double clicking center button to access main menu.
2. Tap the <Up/Down> button until" Preset" is displayed.
3. Double clicking center button to access" Preset", Tap the <Up/Down> button to select " Select prog. ", " Edit prog. ", " Edit Scenes", " Scenes Input" .
4. Double click the center button to confirm or long press the center button to return to the main menu.

Run the auto program: A master fixture can output to three different program signals to the slave fixture to operate. It means the host will send cyclically in the following orders (The host will keep operating the program of Part 1) Then the slave fixture will make the selectively receiving according to its own set.



1. If the slave fixture chooses Run For Slave 1 from the menu of 1-3, then it will receive the part 1's automatic program from link, in the same way, when the slave fixture chooses Run For Slave 2, then it will receive the part 2's automatic program from link.
2. Enter the menu of 1-3 Function Mode---Set To Slave, Here to set machine operate which part of the program during the host-slave connection
3. Enter the menu of 1-4, 1-5 Function Mode---Set To Master
4. Enter the menu of 8-1 Edit Program---Auto Program Part1. The host outputs three groups driven program---Part1, Part2, Part3(Part1 program runs the same effect as the host)
5. Enter the menu of 8-2 Edit Program---Edit Program. Edit the program's connection, connect the scene in order
6. The editor of the scene, there are as many as 250 scenario editors, and every scene can have a program connection of 10.

Note:

Part 2, Part 3 repeat in accordance with the Part1's repeat. For example: When Part 1 uses Program 2, Part 2 uses Program 4, Part 3 uses Program 6, Assume: Program 2 includes scene of 10, 11, 12, 13; Program 4 includes scene of 8, 9, 10; Program 6 includes scene of 12, 13, 14, 15; Then it will run as below.

Example:

Part 1:

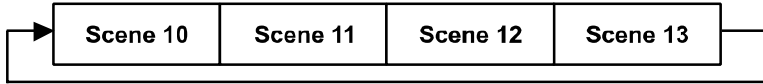

Part 2:

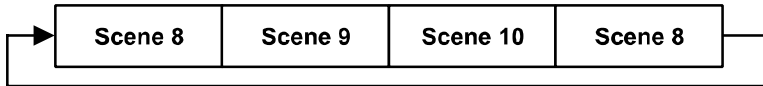

Part 3:

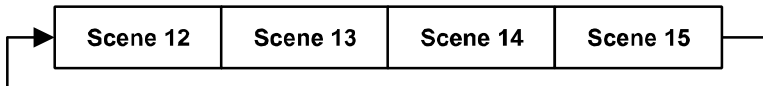

11. DMX PROTOCOL

DMX channel's functions and their values (61DMX channels):				
Mode/Channel			Value	Function
St	Ba	Ex		
1	1	1		<u>PAN Movement 8bit :</u>
			0-255	Pan Movement
2		2		<u>Pan Fine 16bit</u>
			0-255	Fine control of Pan movement
3	2	3		<u>TILT Movement 8bit :</u>
			0-255	Tilt Movement
4		4		<u>Tilt Fine 16bit</u>
			0-255	Fine control of Tilt movement
5	3	5		<u>Speed Pan/Tilt movement:</u>
			0-225	max to min speed
			226-235	blackout by movement
			236-245	blackout by all wheel changing
6	4	6		<u>Shutter, strobe:</u>
			0-10	Shutter closed
			11-20	No function (shutter open)
			21-117	Strobe effect slow to fast
			118-126	No function (shutter open)
127-180	Pulse-effect in sequences			

			181-191	No function (shutter open)
			192-245	Random strobe effect slow to fast
			246-255	No function (shutter open)
7	5	7		<u>Dimmer intensity:</u>
			0-255	Intensity 0 to 100%
		8		<u>Fine Dimmer intensity:</u>
			0-255	Dimmer intensity fine
8	6	9		<u>Chase Patterns:</u>
			0-9	Open
			10-19	Chase 1
			20-29	Chase 2
			30-39	Chase 3
			40-49	Chase 4
			50-59	Chase 5
			60-69	Chase 6
			70-79	Chase 7
			80-89	Chase 8
			90-99	Chase 9
			100-109	Chase 10
			110-119	Chase 11
			120-129	Chase 12
			130-139	Chase 13
			140-255	Reserved
9	7	10		<u>Chase Speed:</u>
			0-125	Fast to Slow Backward
			126-130	Stop(Speed=0)
			131-255	Slow to Fast Forward
10	8	11		<u>Chase Fade:</u>
			0-255	Fade Chase
11	9	12		<u>Zoom :</u>
			0-255	Zoom adjustment from small to big
		13		<u>Zoom Fine:</u>
			0-255	Zoom adjustment Fine
12	10	14		<u>Focus :</u>
			0-255	Continuous adjustment from near to far
		15		<u>Focus Fine:</u>
			0-255	Continuous adjustment Fine
13	11	16		<u>Auto Focus :</u>
			0-50	Auto Focus Off
			51-100	5m
			101-150	7.5m
			151-200	10m
			201-255	15m

14	12	17		<u>AutoFocus Fine:</u>
			0-255	Continuous adjustment Fine
15	13	18		<u>Color Wheel:</u>
			0-3	Open / white
			4-7	Color 1
			8-11	Color 2
			12-15	Color 3
			16-19	Color 4
			20-23	Color 5
			24-27	Color 6
			28-31	Color 7
			32-127	Color indexing
			128-189	Forwards rainbow effect from fast to slow
			190-193	No rotation
		194-255	Backwards rainbow effect from slow to fast	
		19		<u>Color Wheel Fine:</u>
			0-255	Color Wheel colour change to any position Fine
16	14	20		<u>Cyan Color :</u>
			0-255	Cyan (0-white, 255-100% Cyan)
		21		<u>Cyan Color Fine :</u>
			0-255	Cyan Fine
17	15	22		<u>Magenta Color :</u>
			0-255	Magenta (0-white, 255-100% magenta)
		23		<u>Magenta Color Fine :</u>
			0-255	Magenta Fine
18	16	24		<u>Yellow Color :</u>
			0-255	Yellow (0-white, 255-100% Yellow)
		25		<u>Yellow Color Fine :</u>
			0-255	Yellow Fine
19	17	26		<u>CTO Color :</u>
			0-255	CTO (0-white, 255-100% CTO)
		27		<u>CTO Color Fine :</u>
			0-255	CTO Fine
20	18	28		<u>Rotating gobos, cont. rotation 1:</u>
			0-9	Open
			10-19	Rot. gobo 1
			20-29	Rot. gobo 2
			30-39	Rot. gobo 3
			40-49	Rot. gobo 4
			50-59	Rot. gobo 5
			60-69	Rot. gobo 6
			70-77	Rot. Gobo 7
		78-93	Gobo 1 shake slow to fast	

			94-109	Gobo 2 shake slow to fast
			110-125	Gobo 3 shake slow to fast
			126-141	Gobo 4 shake slow to fast
			142-157	Gobo 5 shake slow to fast
			158-173	Gobo 6 shake slow to fast
			174-189	Gobo 7 shake slow to fast
			190-221	Gobo wheel rotation forwards from fast to slow
			222-223	No rotation
			224-255	Gobo wheel rotation f backwards from slow to fast
21	19	29		<u>Rotating gobo index,rotating gobo rotation 1:</u>
			0-127	Gobo indexing
			128-189	Forwards gobo rotation from fast to slow
			190-193	No rotation
			194-255	Backwards gobo rotation from slow to fast
		30		<u>Rotating gobo indexing Fine 1:</u>
			0-255	Fine indexing
22	20	31		<u>Fixed Gobo2 :</u>
			0-13	open
			14-18	Gobo 1
			19-23	Gobo 2
			24-28	Gobo 3
			29-33	Gobo 4
			34-38	Gobo 5
			39-43	Gobo 6
			44-48	Gobo 7
			49-53	Gobo 8
			54-58	Gobo 9
			59-63	Gobo 10
			64-68	Gobo 11
			69-79	Gobo 1 shake slow to fast
			80-90	Gobo 2 shake slow to fast
			91-101	Gobo 3 shake slow to fast
			102-112	Gobo 4 shake slow to fast
			113-123	Gobo 5 shake slow to fast
			124-134	Gobo 6 shake slow to fast
			135-145	Gobo 7 shake slow to fast
			146-156	Gobo 8 shake slow to fast
			157-167	Gobo 9 shake slow to fast
			168-178	Gobo 10 shake slow to fast
			179-189	Gobo 11 shake slow to fast
			190-221	Clock-wise scroll from fast to slow
			222-223	Reserved
			224-255	Counter clock-wise scroll from slow to fast

				<u>Animation wheel:</u>
23	21	32	0-7	open
			8-127	Forwards rotation from fast to slow
			128-135	No rotation
			136-255	Backwards rotation from slow to fast
24	22	33		<u>Iris:</u>
			0-191	Max. diameter to Min.diameter
			192-223	Pulse closing fast to slow
		224-255	Pulse opening slow to fast	
		34		<u>Iris Fine:</u>
			0-255	Iris Fine
25	23	35		<u>Prism 1:</u>
			0-127	Open
			128-255	5-Facet Prism
26	24	36		<u>Rotating prism index, rotating prism rotation 1</u>
			0-127	Prism indexing
			128-189	Forwards prism rotation from fast to slow
			190-193	No rotation
			194-255	Backwards prism rotation from slow to fast
		37		<u>Rotating prism indexing Fine 1:</u>
			0-255	Fine indexing
27	25	38		<u>Prism 2:</u>
			0-127	Open
			128-255	Linear Prism
28	26	39		<u>Rotating prism index, rotating prism rotation 2</u>
			0-127	Prism indexing
			128-189	Forwards prism rotation from fast to slow
			190-193	No rotation
			194-255	Backwards prism rotation from slow to fast
		40		<u>Rotating prism indexing Fine 2:</u>
			0-255	Fine indexing
29	27	41		<u>Frost 1:</u>
			0-255	0-100%
30	28	42		<u>Frost 2:</u>
			0-255	0-100%
31	29	43		<u>Blade 1A :</u>
			0-255	Open to Close
		44		<u>Blade 1A Fine :</u>
			0-255	Open to Close Fine
32	30	45		<u>Blade 1B _____ :</u>
			0-255	Open to Close
		46		<u>Blade 1B Fine _____ :</u>
			0-255	Open to Close Fine

33	31	47		Blade 2A :
			0-255	Open to Close
		48		Blade 2A Fine :
			0-255	Open to Close Fine
34	32	49		Blade 2B :
			0-255	Open to Close
		50		Blade 2B Fine :
			0-255	Open to Close Fine
35	33	51		Blade 3A :
			0-255	Open to Close
		52		Blade 3A Fine :
			0-255	Open to Close Fine
36	34	53		Blade 3B :
			0-255	Open to Close
		54		Blade 3B Fine :
			0-255	Open to Close Fine
37	35	55		Blade 4A :
			0-255	Open to Close
		56		Blade 4A Fine :
			0-255	Open to Close Fine
38	36	57		Blade 4B :
			0-255	Open to Close
		58		Blade 4B Fine :
			0-255	Open to Close Fine
39	37	59		All Blade Rotation :
			0-255	All Blade Rotation
		60		All Blade Rotation Fine :
			0-255	All Blade Rotation Fine
40	38	61		Control, reset, internal programs:
			0-4	unused
			5-9	Display Off
			10-14	Display On
			15-19	Display Invert Off
			20-24	Display Invert On
			25-29	Auto fan control mode
			30-34	Stage fan control mode
			35-39	Studio fan control mode
			40-44	Silence fan control mode
			45-49	Square Law
			50-54	Linear
			55-59	1.2K
			60-64	2.4K
			65-69	16K
70-74	Gobo correction Off			
75-79	Gobo correction On			

		80-84	All motor reset
		85-87	Scan motor reset
		88-90	Colors motor reset
		91-93	Gobo motor reset
		94-96	unused
		97-99	Other motor reset
		100-119	Internal program 1 (scene1~8 of EEPROM)
		120-139	Internal program 2 (scene9~16 of EEPROM)
		140-159	Internal program 3 (scene17~24 of EEPROM)
		160-179	Internal program 4 (scene25~32 of EEPROM)
		180-199	Internal program 5 (scene33~40 of EEPROM)
		200-219	Internal program 6 (scene41~48 of EEPROM)
		220-239	Internal program 7 (scene49~56 of EEPROM)
		240-255	Internal program 8 (scene57~64 of EEPROM)

DMX channel's functions and their values:		
Mode/Channel	Value	Function
Ghibli Mode		
1		<u>PAN Movement 8bit :</u>
	0-255	Pan Movement
2		<u>Pan Fine 16bit</u>
	0-255	Fine control of Pan movement
3		<u>TILT Movement 8bit :</u>
	0-255	Tilt Movement
4		<u>Tilt Fine 16bit</u>
	0-255	Fine control of Tilt movement
5		<u>Speed Pan/Tilt movement:</u>
	0-225	max to min speed
	226-235	blackout by movement
	236-245	blackout by all wheel changing
	246-255	no function
6		<u>Shutter, strobe:</u>
	0-10	Shutter closed
	11-20	No function (shutter open)
	21-117	Strobe effect slow to fast
	118-126	No function (shutter open)
	127-180	Pulse-effect in sequences
	181-191	No function (shutter open)
	192-245	Random strobe effect slow to fast
246-255	No function (shutter open)	
7		<u>Dimmer intensity:</u>
	0-255	Intensity 0 to 100%
8		<u>Fine Dimmer intensity:</u>
	0-255	Dimmer intensity fine
9		<u>Chase Patterns:</u>
	0-9	Open
	10-19	Chase 1
	20-29	Chase 2
	30-39	Chase 3
	40-49	Chase 4
	50-59	Chase 5
	60-69	Chase 6
	70-79	Chase 7
	80-89	Chase 8
	90-99	Chase 9
	100-109	Chase 10
	110-119	Chase 11
	120-129	Chase 12
	130-139	Chase 13
140-255	Reserved	
10		<u>Chase Speed:</u>
	0-125	Fast to Slow Backward
	126-130	Stop(Speed=0)

	131-255	Slow to Fast Forward
11		<u>Chase Fade:</u>
	0-255	Fade Chase
12		<u>Zoom :</u>
	0-255	Zoom adjustment from small to big
13		<u>Zoom Fine:</u>
	0-255	Zoom adjustment Fine
14		<u>Focus :</u>
	0-255	Continuous adjustment from near to far
15		<u>Focus Fine:</u>
	0-255	Continuous adjustment Fine
16		<u>Auto Focus :</u>
	0-50	Auto Focus Off
	51-100	5m
	101-150	7.5m
	151-200	10m
17		<u>AutoFocus Fine:</u>
	0-255	Continuous adjustment Fine
18		<u>Color Wheel:</u>
	0-3	Open / white
	4-7	Color 1
	8-11	Color 2
	12-15	Color 3
	16-19	Color 4
	20-23	Color 5
	24-27	Color 6
	28-127	Color indexing
	128-189	Forwards rainbow effect from fast to slow
	190-193	No rotation
194-255	Backwards rainbow effect from slow to fast	
19		<u>Color Wheel Fine:</u>
	0-255	Color Wheel colour change to any position Fine
20		<u>Cyan Color :</u>
	0-255	Cyan (0-white, 255-100% Cyan)
21		<u>Cyan Color Fine :</u>
	0-255	Cyan Fine
22		<u>Magenta Color :</u>
	0-255	Magenta (0-white, 255-100% magenta)
23		<u>Magenta Color Fine :</u>
	0-255	Magenta Fine
24		<u>Yellow Color :</u>
	0-255	Yellow (0-white, 255-100% Yellow)
25		<u>Yellow Color Fine :</u>
	0-255	Yellow Fine
26		<u>CTO Color :</u>
	0-255	CTO (0-white, 255-100% CTO)
27		<u>CTO Color Fine :</u>

	0-255	CTO Fine
28		<u>Rotating gobos, cont. rotation 1:</u>
	0-9	Open
	10-19	Rot. gobo 1
	20-29	Rot. gobo 2
	30-39	Rot. gobo 3
	40-49	Rot. gobo 4
	50-59	Rot. gobo 5
	60-69	Rot. gobo 6
	70-77	Rot. Gobo 7
	78-93	Gobo 1 shake slow to fast
	94-109	Gobo 2 shake slow to fast
	110-125	Gobo 3 shake slow to fast
	126-141	Gobo 4 shake slow to fast
	142-157	Gobo 5 shake slow to fast
	158-173	Gobo 6 shake slow to fast
	174-189	Gobo 7 shake slow to fast
	190-221	Gobo wheel rotation forwards from fast to slow
	222-223	No rotation
224-255	Gobo wheel rotation f backwards from slow to fast	
29		<u>Rotating gobo index,rotating gobo rotation 1:</u>
	0-127	Gobo indexing
	128-189	Forwards gobo rotation from fast to slow
	190-193	No rotation
194-255	Backwards gobo rotation from slow to fast	
30		<u>Rotating gobo indexing Fine 1:</u>
	0-255	Fine indexing
31		<u>Fixed Gobo2 :</u>
	0-21	open
	22-31	Gobo 1
	32-41	Gobo 2
	42-51	Gobo 3
	52-61	Gobo 4
	62-71	Gobo 5
	72-81	Gobo 6
	82-91	Gobo 7
	92-101	Gobo 8
	102-112	Gobo 1 shake slow to fast
	113-123	Gobo 2 shake slow to fast
	124-134	Gobo 3 shake slow to fast
	135-145	Gobo 4 shake slow to fast
	146-156	Gobo 5 shake slow to fast
	157-167	Gobo 6 shake slow to fast
	168-178	Gobo 7 shake slow to fast
	179-189	Gobo 8 shake slow to fast
190-221	Clock-wise scroll from fast to slow	
222-223	Reserved	
224-255	Counter clock-wise scroll from slow to fast	

32		<u>Animation wheel:</u>
	0-7	open
	8-127	Forwards rotation from fast to slow
	128-135	No rotation
33	136-255	Backwards rotation from slow to fast
		<u>Iris:</u>
	0-191	Max. diameter to Min.diameter
	192-223	Pulse closing fast to slow
34	224-255	Pulse opening slow to fast
		<u>Iris Fine:</u>
35	0-255	Iris Fine
		<u>Prism 1:</u>
	0-127	Open
36	128-255	5-Facet Prism
		<u>Rotating prism index, rotating prism rotation 1</u>
	0-127	Prism indexing
	128-189	Forwards prism rotation from fast to slow
	190-193	No rotation
37	194-255	Backwards prism rotation from slow to fast
		<u>Rotating prism indexing Fine 1:</u>
38	0-255	Fine indexing
		<u>Frost 1:</u>
39	0-255	0-100%
		<u>Frost 2:</u>
40	0-255	0-100%
		<u>Blade 1A :</u>
41	0-255	Open to Close
		<u>Blade 1A Fine :</u>
42	0-255	Open to Close Fine
		<u>Blade 1B :</u>
43	0-255	Open to Close
		<u>Blade 1B Fine :</u>
44	0-255	Open to Close Fine
		<u>Blade 2A :</u>
45	0-255	Open to Close
		<u>Blade 2A Fine :</u>
46	0-255	Open to Close Fine
		<u>Blade 2B :</u>
47	0-255	Open to Close
		<u>Blade 2B Fine :</u>
48	0-255	Open to Close Fine
		<u>Blade 3A :</u>
49	0-255	Open to Close
		<u>Blade 3A Fine :</u>
50	0-255	Open to Close Fine
		<u>Blade 3B :</u>
51	0-255	Open to Close
		<u>Blade 3B Fine :</u>

	0-255	Open to Close Fine
52		Blade 4A :
	0-255	Open to Close
53		Blade 4A Fine :
	0-255	Open to Close Fine
54		Blade 4B :
	0-255	Open to Close
55		Blade 4B Fine :
	0-255	Open to Close Fine
56		All Blade Rotation :
	0-255	All Blade Rotation
57		All Blade Rotation Fine :
	0-255	All Blade Rotation Fine
58		Control, reset, internal programs:
	0-4	unused
	5-9	Display Off
	10-14	Display On
	15-19	Display Invert Off
	20-24	Display Invert On
	25-29	Auto fan control mode
	30-34	Stage fan control mode
	35-39	Studio fan control mode
	40-44	Silence fan control mode
	45-49	Square Law
	50-54	Linear
	55-59	1.2K
	60-64	2.4K
	65-69	16K
	70-74	Gobo correction Off
	75-79	Gobo correction On
	80-84	All motor reset
	85-87	Scan motor reset
	88-90	Colors motor reset
	91-93	Gobo motor reset
	94-96	unused
	97-99	Other motor reset
	100-119	Internal program 1 (scene1~8 of EEPROM)
	120-139	Internal program 2 (scene9~16 of EEPROM)
	140-159	Internal program 3 (scene17~24 of EEPROM)
	160-179	Internal program 4 (scene25~32 of EEPROM)
	180-199	Internal program 5 (scene33~40 of EEPROM)
	200-219	Internal program 6 (scene41~48 of EEPROM)
	220-239	Internal program 7 (scene49~56 of EEPROM)
240-255	Internal program 8 (scene57~64 of EEPROM)	

12. ERROR MESSAGES

When you turn on the device, it will first perform a reset. The display may show " Err channel is XX" should there be problems with one or more functions. " XX" stands for channel 1, 2, 3, 4, 5, 6 etc whose sensor has encountered a problem. For example, when the display shows " Err channel is Pan movement", it means there is an error on channel 1. If there are errors on channel 1, channel 3, channel 6 at the same time, you may see the error message, " Err channel is Pan movement", " Err channel is Tilt movement" " Err channel is Shutter", flash twice, and then the device will generate a second reset. If the error messages persist after performing a reset more than twice, the channels which have errors may not work properly however, all other functions can work as usual. Please contact your dealer or manufacturer for service. Self repair is not allowed.

PAN- movement Er

(PAN- yoke movement error) This message will appear after the reset of the fixture if the yoke's magnetic-indexing circuit malfunction (Optical Sensor or Magnetic Sensor fails) or the stepper motor is defective (or its driving IC on the main PCB). The PAN- movement is not located in the default position after the reset.

TILT- movement Er

(TILT- head movement error) This message will appear after the reset of the fixture if the head's magnetic-indexing circuit malfunctions ((Optical Sensor or Magnetic Sensor fails)) or the stepper motor is defective (or its driving IC on the main PCB). The TILT- movement is not located in the default position after the reset.

Zoom wheel Er

(Zoom wheel error) This message will appear after the reset of the fixture if the head's magnetic-indexing circuit malfunctions (Optical Sensor or Magnetic Sensor fails) or the stepper motor is defective (or its driving IC on the main PCB). The Zoom - movement is not located in the default position after the reset.

Focus wheel Er

(Focus wheel error) This message will appear after the reset of the fixture if the head's magnetic-indexing circuit malfunctions (Optical Sensor or Magnetic Sensor fails) or the stepper motor is defective (or its driving IC on the main PCB). The Focus - movement is not located in the default position after the reset.

Color wheel Er

(Color wheel- error) This message will appear after the reset of the fixture if the head's magnetic-indexing circuit malfunctions (sensor failed or magnet missing) or the stepper motor is defective (or its driving IC on the main PCB). The Color - movement is not located in the default position after the reset.

Cyan Color wheel Er

(Cyan Color wheel- error) This message will appear after the reset of the fixture if the head's magnetic-indexing circuit malfunctions (sensor failed or magnet missing) or the stepper motor is defective (or its driving IC on the main PCB). The CMY - movement is not located in the default position after the reset.

Magenta Color wheel Er

(Magenta Color wheel- error) This message will appear after the reset of the fixture if the head's magnetic-indexing circuit malfunctions (sensor failed or magnet missing) or the stepper motor is defective (or its driving IC on the main PCB). The CMY - movement is not located in the default position after the reset.

Yellow Color wheel Er

(Yellow Color wheel- error) This message will appear after the reset of the fixture if the head's magnetic-indexing circuit malfunctions (sensor failed or magnet missing) or the stepper motor is defective (or its driving IC on the main PCB). The CMY - movement is not located in the default position after the reset.

CTO wheel Er

(CTO wheel- error) This message will appear after the reset of the fixture if the head's magnetic-indexing circuit malfunctions (sensor failed or magnet missing) or the stepper motor is defective (or its driving IC on the main PCB). The CTO - movement is not located in the default position after the reset.

Rot_Gobo1 wheel Er

(Rot_Gobo1 wheel - error) This message will appear after the reset of the fixture if the head's magnetic-indexing circuit malfunctions (sensor failed or magnet missing) or the stepper motor is defective (or its driving IC on the main PCB). The Rot_Gobo1 - movement is not located in the default position after the reset.

Rot_Gobo2 wheel Er

(Rot_Gobo2 wheel - error) This message will appear after the reset of the fixture if the head's magnetic-indexing circuit malfunctions (sensor failed or magnet missing) or the stepper motor is defective (or its driving IC on the main PCB). The Rot_Gobo2 - movement is not located in the default position after the reset.

Animation wheel Er

(Animation wheel - error) This message will appear after the reset of the fixture if the head's magnetic-indexing circuit malfunctions (sensor failed or magnet missing) or the stepper motor is defective (or its driving IC on the main PCB). The Animation - movement is not located in the default position after the reset.

Iris wheel Er

(Iris wheel - error) This message will appear after the reset of the fixture if the head's magnetic-indexing circuit malfunctions (sensor failed or magnet missing) or the stepper motor is defective (or its driving IC on the main PCB). The Iris - movement is not located in the default position after the reset.

Prism_3 wheel Er

(Prism_3 wheel- error) This message will appear after the reset of the fixture if the head's magnetic-indexing circuit malfunctions (sensor failed or magnet missing) or the stepper motor is defective (or its driving IC on the main PCB). The Prism_3 - movement is not located in the default position after the reset.

Prism_5 wheel Er

(Prism_5 wheel - error) This message will appear after the reset of the fixture if the head's magnetic-indexing circuit malfunctions (sensor failed or magnet missing) or the stepper motor is defective (or its driving IC on the main PCB). The Prism_5 - movement is not located in the default position after the reset.

Frost 1 wheel Er

(Frost 1 wheel - error) This message will appear after the reset of the fixture if the head's magnetic-indexing circuit malfunctions (sensor failed or magnet missing) or the stepper motor is defective (or its driving IC on the main PCB). The Frost 1 - movement is not located in the default position after the reset.

Blade 1 wheel Er

(Blade 1 wheel - error) This message will appear after the reset of the fixture if the head's magnetic-indexing circuit malfunctions (sensor failed or magnet missing) or the stepper motor is defective (or its driving IC on the main PCB). The Blade 1 - movement is not located in the default position after the reset.

Blade 1_Rot wheel Er

(Blade 1_Rot wheel - error) This message will appear after the reset of the fixture if the head's magnetic-indexing circuit malfunctions (sensor failed or magnet missing) or the stepper motor is defective (or its driving IC on the main PCB). The Blade 1_Rot - movement is not located in the default position after the reset.

Blade 2 wheel Er

(Blade 2 wheel - error) This message will appear after the reset of the fixture if the head's magnetic-indexing circuit malfunctions (sensor failed or magnet missing) or the stepper motor is defective (or its driving IC on the main PCB). The Blade 2 - movement is not located in the default position after the reset.

Blade 2_Rot wheel Er

(Blade 2_Rot wheel - error) This message will appear after the reset of the fixture if the head's magnetic-indexing circuit malfunctions (sensor failed or magnet missing) or the stepper motor is defective (or its driving IC on the main PCB). The Blade 2_Rot - movement is not located in the default position after the reset.

Blade 3 wheel Er

(Blade 3 wheel - error) This message will appear after the reset of the fixture if the head's magnetic-indexing circuit malfunctions (sensor failed or magnet missing) or the stepper motor is defective (or its driving IC on the main PCB). The Blade 3 - movement is not located in the default position after the reset.

Blade 3_Rot wheel Er

(Blade 3_Rot wheel - error) This message will appear after the reset of the fixture if the head's magnetic-indexing circuit malfunctions (sensor failed or magnet missing) or the stepper motor is defective (or its driving IC on the main PCB). The Blade 3_Rot - movement is not located in the default position after the reset.

Blade 4 wheel Er

(Blade 4 wheel - error) This message will appear after the reset of the fixture if the head's magnetic-indexing circuit malfunctions (sensor failed or magnet missing) or the stepper motor is defective (or its driving IC on the main PCB). The Blade 4 - movement is not located in the default position after the reset.

Blade 4_Rot wheel Er

(Blade 4_Rot wheel - error) This message will appear after the reset of the fixture if the head's magnetic-indexing circuit malfunctions (sensor failed or magnet missing) or the stepper motor is defective (or its driving IC on the main PCB). The Blade 4_Rot - movement is not located in the default position after the reset.

All_Blade _Rot wheel Er

(All_Blade _Rot wheel - error) This message will appear after the reset of the fixture if the head's magnetic-indexing circuit malfunctions (sensor failed or magnet missing) or the stepper motor is defective (or its driving IC on the main PCB). The All_Blade _Rot - movement is not located in the default position after the reset.

Frost 2 wheel Er

(Frost 2 wheel - error) This message will appear after the reset of the fixture if the head's magnetic-indexing circuit malfunctions (sensor failed or magnet missing) or the stepper motor is defective (or its driving IC on the main PCB). The Frost 2 - movement is not located in the default position after the reset.

Animation_Rot wheel Er

(Animation_Rot wheel - error) This message will appear after the reset of the fixture if the head's magnetic-indexing circuit malfunctions (sensor failed or magnet missing) or the stepper motor is defective (or its driving IC on the main PCB). The Animation_Rot - movement is not located in the default position after the reset.

13. CLEANING AND MAINTENANCE

The following points have to be considered during inspection:

- 1) All screws for installing the devices or parts of the device have to be tightly connected and must not be corroded.
 - 2) There must not be any deformations to the housing, lenses, rigging and installation points (ceiling, suspension, trussing).
 - 3) Motorized parts must not show any signs of wear and must move smoothly without issue.
 - 4) The power supply cables must not show any damage, material fatigue or sediment.
- Further instructions depending on the installation location and usage have to be adhered to by a qualified installer and any safety concerns have to be removed.



CAUTION!

Disconnect from mains before starting maintenance operation.

In order to ensure the device remains in good condition and does not fail prematurely, we suggest regular maintenance.

- 1) Clean the inside and outside lens each week to avoid loss of output due to accumulation of dust/ dirt on the lens.
- 2) Clean the fans each week to ensure maximum airflow and efficient thermal cooling. This will ensure the light source is operated in the best possible condition.
- 3) A detailed electrical check by an approved electrician every quarter to make sure that the circuit contacts are in good condition. This will prevent poor circuit contacts and the resultant overheating.

We recommend frequent cleaning of the device. Please use a moist, lint- free cloth. Never use alcohol or solvents.

Please refer to the instructions under " Installation instructions" .

Should you need any spare parts, please order genuine parts from your local dealer.

Remark: Errors and omissions for all information given in this manual are excepted. All information is subject to change without prior notice.

